



GENERATING SET GE 90 PSX

The images are for reference



FEATURES

- Bundled base suitable to contain any liquids leakage from engine avoiding environmental pollution
- Oil drain pump
- Fuel pre-filter with water separator
- Large doors for better and easy maintenance (air, oil, fuel filters replacement)
- Single point lifting eye
- Control panel with digital control unit available with automatic or manual version
- Meets EC directives for noise and safety



water cooled



diesel



three-phase power



electric



super silenced

POWER RATINGS

* Stand-By three-phase power (LTP)	90 kVA (72 kW) / 400 V / 130 A
* PRP three-phase power	82 kVA (65.6 kW) / 400 V / 118.3 A
* PRP single-phase power	/
* COP power	/
Frequency	50 Hz
Cos φ	0.8

* Output powers according to ISO 8528-1

DEFINITION

Valid declared powers up to the followings environmental conditions: temperature 25°C, altitude 100 meters above sea level)

LTP power: stand-by power: Maximum available power for use with variable loads for a yearly number of hours limited at 500 h. No overload is admitted.

PRP power: continue power with variable loads. Maximum power for use with variable loads for a yearly illimited nubers of hours.

COP power: continuous power with constant load. Maximum power for use with constant loads for a yearly unlimited numbers of hours.

ENGINE 1500 RPM

4 STROKE, DIRECT INJECTION, TURBOCHARGED

Model	PERKINS 1104A-44TG2
* Stand-By net power	79.1 kWm (107.6 hp)
* PRP net power	71.9 kWm (97.8 hp)
* COP net power	/
Cylinders / Displacement	4 / 4400 cm ³ (4.4 lt.)
Bore / Stroke	105 / 127 (mm)
Compression ratio	17.25 : 1
BMEP (Brake Mean Effective Pressure : LTP - PRP)	1467 kPa - 1335 kPa
Speed governor type	Mechanical
FUEL CONSUMPTION	
110 % (Stand-by power)	218 g/kWh - 20.5 lt./h
100 % to PRP	218 g/kWh - 18.7 lt./h
75 % to PRP	218 g/kWh - 14 lt./h
50 % to PRP	226 g/kWh - 9.7 lt./h
COOLING SYSTEM	
Total system cap. - only engine	13 lt - 7 lt.
Fan air flow	89 m ³ /min.
LUBRICATION SYSTEM	
Total oil system capacity	8 lt
Oil capacity in sump	7 lt ÷ 5.5 lt
Oil consumption at full load	< 0.030 lt./h

* Potenze dichiarate in accordo a ISO 3046-1

EXHAUST SYSTEM

Maximum exhaust gas flow	13.3 m ³ /min.
Max. exhaust gas temp.	580 °C
Maximum back pressure	10 kPa (0.10 bar)
External diameter exhaust pipe	/
ELECTRICAL SYSTEM	
Starter motor power	3 kW
Battery charging alternator cap.	65 A
Cold start	- 10°C
With cold start aid	- 25 °C
AIR FILTER	
Combustion air flow	5.14 m ³ /min
HEAT REJECTED AT FULL LOAD	
To exhaust system	59 kW - 3358 Btu/min.
To water and oil	51 kW - 2902 Btu/min.
Radiated to room	14 kW - 797 Btu/min.
To charge cooler	/



ALTERNATOR

SYNCHRONOUS, THREE-PHASE, SELF-EXCITED, SELF-REGULATED, BRUSHLESS	
Continuous power	85 kVA
Stand-by power	94 kVA
Three phase voltage	380-415 Vac
Frequency	50 Hz
Cos φ	0.8
Model A.V.R.	MARK V (M16FA655A)
Voltage regulation acc.	± 0.5 %
Sustained short circuit current	370 A
Transient dip (100% load)	< 20 %
Recovery time	< 0.3 sec
Efficiency at 100% load	91 % (400V - Cos φ 0.8)
Insulation	Class H
Connection - Terminals	Star - N°12
Electromagnetic compatibility (R.F.I. suppr.)	EN55011
Waveform distortion - THD	< 2 %
Telephone interference - THF	< 2 %

REACTANCES (220 kVA - 400V)	
Direct axis synchronous - X _d	285 %
Direct axis transient - X' _d	22.5 %
Subdirect axis transient - X'' _d	10.8 %
Quadrature axis synchronous - X _q	160 %
Quadr. axis subtransient - X'' _q	12 %
Negative sequence - X ₂	11.4 %
Zero sequence - X ₀	2.5 %
TIME CONSTANTS	
Transient - T' _d	0.071 sec
Subtransient - T'' _d	0.005sec
Open circuit - T' _{do}	0.82 sec
Armature - T _a	0.005 sec
Short-circuit ratio K _{cc}	0.38
Cooling air flow	0.31 m ³ /sec.
Coupling Bearing	Direct SAE 3 -11 ½ - N°1

GENERAL SPECIFICATIONS

Fuel tank capacity	230 lt
Running time (75% to PRP)	16 h
Starter battery	12 Vdc -100Ah
IP protection degree	IP 44

* Measured acoustic power L _{WA} (pressure L _{pA})	92 dB(A) (67 dB(A) @ 7m)
* Guaranteed acoustic power L _{WA} (pressure L _{pA})	94 dB(A) (69 dB(A) @ 7m)
Performance class (ISO 8528)	G2

* Acoustic power according to European Directive 2000/14/CE

CONTROL PANEL

- Controller AMF 25
- Controller supply switch
- Siren
- Emergency stop button
- TCM 35 remote control plug
- Four pole circuit breaker
- PAC (ATS) plug - Automatic control panel only
- Battery charger - Automatic control panel only
- Earth terminal (PE)



AMF25 CONTROLLER CHARACTERISTICS	
Operating mode	<ul style="list-style-type: none"> • OFF - MAN. - AUTO - TEST
Display	<ul style="list-style-type: none"> • Graphic back-light LCD display 128x64 pixels
LEDs	<ul style="list-style-type: none"> • Gen-set voltage OK • Gen-set failure • GCB ON (only for Automatic transfer unit) • Mains voltage OK (only for Automatic transfer unit) • Mains failure (only for Automatic transfer unit) • MCB ON (only for Automatic transfer unit)
Buttons	<ul style="list-style-type: none"> • START button • STOP button • FAULT RESET button • RESET HORN button • MODE selection button • Pulsante chiusura/apertura GCB button • Pulsante chiusura/apertura MCB button • N° 4 buttons for controller programming
Generator Measures	<ul style="list-style-type: none"> • Voltage : L1-L2 / L2-L3 / L3-L1 - N-L1/N-L2/N-L3 • Current : I1 - I2 - I3 • Powers : kVA - kW - kVAR (totali e per fase) • Energy : kVAh - kWh - kVARh • Cos φ (medium and per phase) • Frequency
Engine Measures	<ul style="list-style-type: none"> • Water temperature • Oil pressure • Fuel level • Rpm meter • Battery voltage • Maintenance • Hours meter • Starts number
Generator Protections	<ul style="list-style-type: none"> • Overload • Overcurrent • Short circuit • Over-Undervoltage • Over-Underfrequency • Voltage asymmetry • Unbalanced current • Phase sequence
Engine Protections	<ul style="list-style-type: none"> • Overspeed • High water temperature warning • Low oil pressure warning • Low fuel level warning • Over-Under battery voltage • Battery charge alternator failure • Start failure • Stop failure • Emergency stop • Low water level shutdown (option)

AMF functions (Automatic control panel only)	<ul style="list-style-type: none"> • Measure mains voltage : L1-L2 / L2-L3 / L3-L1 - N-L1/N-L2/N-L3 • Measure mains frequency • Three phase detection • Over-Under mains voltage • Over-Under mains frequency • Voltage asymmetry • Phase sequence • Dual mutual stand-by application
Features	<ul style="list-style-type: none"> • Event log and alarms • 2 tests run scheduler (Automatic test or scheduled starts) • Engine idle management (Idle) • Remote Start and Stop • Pre-heating • 2 selectable languages (other languages available) • Setpoints adjustable via controller buttons or PC • Direct connection to engines with ECU via Can bus J1939 • Configurable inputs and outputs (only via PC) • IP65 protection • Operation temperature: -20°C / +70°C
Communication	<ul style="list-style-type: none"> • RTU Modbus (optional board with RS232 & RS485 outputs is needed) • TCP/IP Modbus (optional Ethernet board with RJ45 output is needed) • SNMP Modbus (optional Ethernet board with RJ45 output is needed) • Internet (optional Ethernet board optional is needed) • GSM/GPRS (integrated Modem board optional is needed) for Gen-set remote control via SMS or internet

CONTROL PANEL VERSION WITH OUTPUT SOCKETS	
SOCKETS Each socket is protect by own automatic switch. Circuit breaker for 125A and 63A sockets. GFI and circuit breaker 30mA for 32A and 16A socket.	1x 400V 125A 3P+T CEE 1x 400V 63A 3P+T CEE 1x 400V 32A 3P+T CEE 1x 400V 16A 3P+T CEE 1x 230V 16A 2P+T CEE 1x 230V 16A 2P+T SCHUKO



WEIGHT - DIMENSIONS AND ACCESSORIES

GE 90 PSX



DRY WEIGHT MACHINE:

- 1540 Kg

Generating set pictured may include optional accessories.



DIMENSIONS DRAW

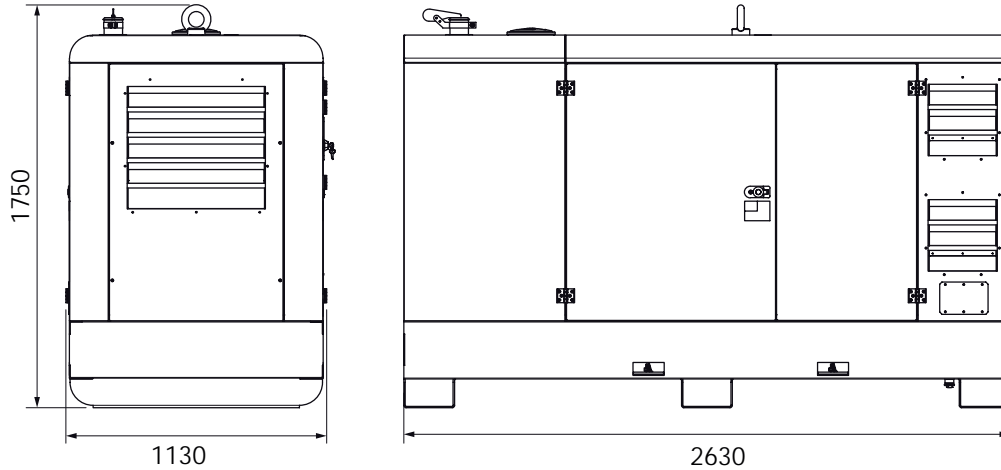

OPTIONS ON REQUEST

- Automatic transfer switch unit (ATS) PAC 111M (160A)
- Remote control TCM35
- Earthing kit



VERSIONS ON REQUEST

- Version with manual control panel 6 output sockets EC and SCHUKO (see Control board with output sockets section)
- Manual digital control panel (without sockets)



FACTORY INSTALLATION OPTIONS

- Engine water heater WH
- Spark arrestor
- Tank 350l
- 3-way valve fuel system with quick connection for external fuel tank supply
- Main battery switch
- Low level water sensor
- Electronic leakage relay
- Isometer
- Volt adjustable from control panel
- Plug-in board with RS232 & RS485 output for RTU Modbus protocol
- Ethernet plug-in board with RJ45 output for TCP/IP Modbus protocol - SNMP Modbus - Internet
- Plug-in board with integrated GSM/GPRS Modem for Gen-set remote control via SMS or Internet

GENERAL INFORMATION

COMPLIANCE GENERATING SETS WITH EC DIRECTIVES AND STANDARDS

- 2006/42 / EC (Machines Directive)
- 2014/35 / EU (Low Voltage Directive)
- 2014/30 / EU (EMC Directive)
- 2000/14 / EC (Directive Acoustic Emission for machines for use outdoors)
- ISO 8528 (Reciprocating internal combustion engine driven alternating current generating sets)



ISO 9001:2015 - Cert. 0192

WARRANTY

All devices are covered by the manufacturer's warranty.

The company reserves the right to change this specification without notice. For further information please contact the sales department.

© MOSA - Viale Europa, 59 - 20090 Cusago (Milano) - Italy - phone +39-0290352.1 - fax +39-0290390466 E-mail: info@mosa.it Web site: www.mosa.it

